

PLURIJET

self-priming multi-stage pumps

New self-priming pumps, quiet running, reliable, high efficiency, patented.



RANGE OF PERFORMANCE

Flow rate up to 52 gpm
Head up to 394 ft

LIMITS OF USE

Manometric suction lift up to 29 ft
Liquid temperature up to + 104°F
Environment temperature up to + 104°F

CONSTRUCTION AND SAFETY STANDARDS

EN 60 335-1	EN 60034-1
IEC 335-1	IEC 34-1
CEI 61-150	CEI 2-3



INSTALLATION AND USE

They are recommended for clean water and liquids that are chemically non aggressive to the materials from which the pump is made.

PLURIJET SELF-PRIMING PUMPS ARE DESIGNED FOR LIFTING WATER, EVEN IN CASES WITH ENTRAINED AIR. THEIR QUIET RUNNING, RELIABILITY AND LOW POWER CONSUMPTION MAKES THEM PARTICULARLY SUITABLE FOR DOMESTIC AND CIVIL USE, INCLUDING PRESSURISATION AND DISTRIBUTION OF WATER, IRRIGATION AND RAINWATER RECOVERY SYSTEMS.

The pumps must be installed in enclosed places, or at least protected against inclement weather.

GUARANTEE 2 YEARS subject to our general terms of sale.

CONSTRUCTION CHARACTERISTICS

- **PUMP BODY:** cast iron and stainless steel AISI 304 (cast iron up to 0.7 HP), with threaded ports.
- **IMPELLER:** technopolymer (approved for drinking water).
- **MOTOR SHAFT:** stainless steel EN 10088-3 - 1.4104
- **MECHANICAL SEAL:** ceramic - graphite - NBR.
- **ELECTRIC MOTOR:** the pumps are close-coupled to a carefully matched PEDROLLO electric motor, quiet running, totally enclosed fan cooled (TEFC), suitable for continuous duty.
PLURIJETm: single-phase 115 V or 230 V - 60 Hz with capacitor and thermal overload protector.
PLURIJET: three-phase 230/460 V - 60 Hz.
- **INSULATION:** class F. ● **PROTECTION:** IP 44.
- **REGISTERED MODEL**

OPTIONS ON REQUEST

- ⇒ version in stainless steel EN 10088-3 - 1.4401 (AISI 316)
- ⇒ other voltages or frequency 50 Hz

CURVES AND PERFORMANCE DATA

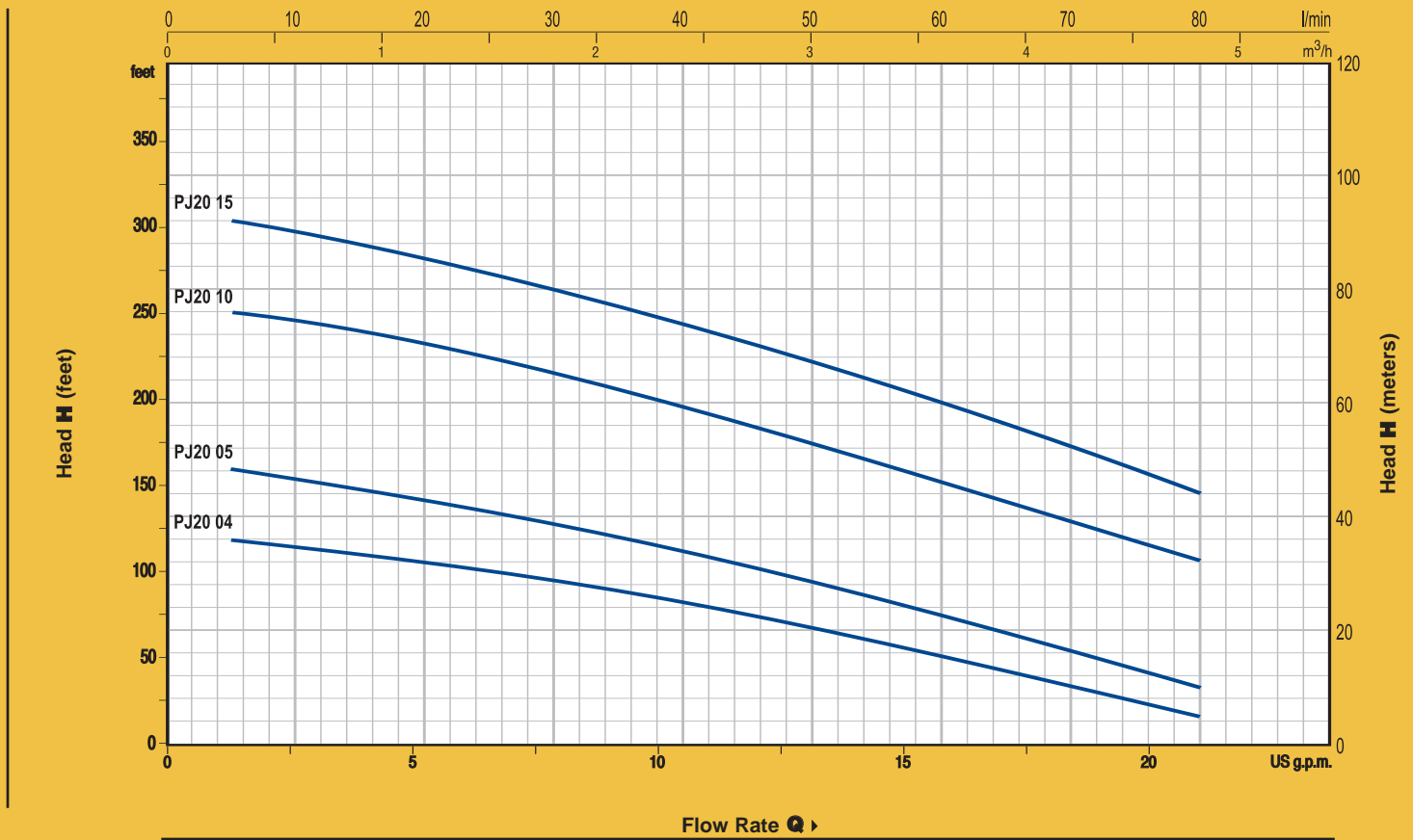

MODEL		HP	FLOW RATE GPM												
1 PH	3 PH		0	1	2	7	7	10	13	15	18	21			
PJ20 04	PJ20 04	0.4	125	118	113	105	95	82	66	51	34	16			
PJ20 05	PJ20 05	0.5	164	158	153	141	126	110	92	74	54	33			
PJ20 10	PJ20 10	1.0	250	250	241	230	215	209	177	154	133	108			
PJ20 15	PJ20 15	1.5	306	306	297	283	266	245	220	195	171	141			

DIMENSIONS AND WEIGHT

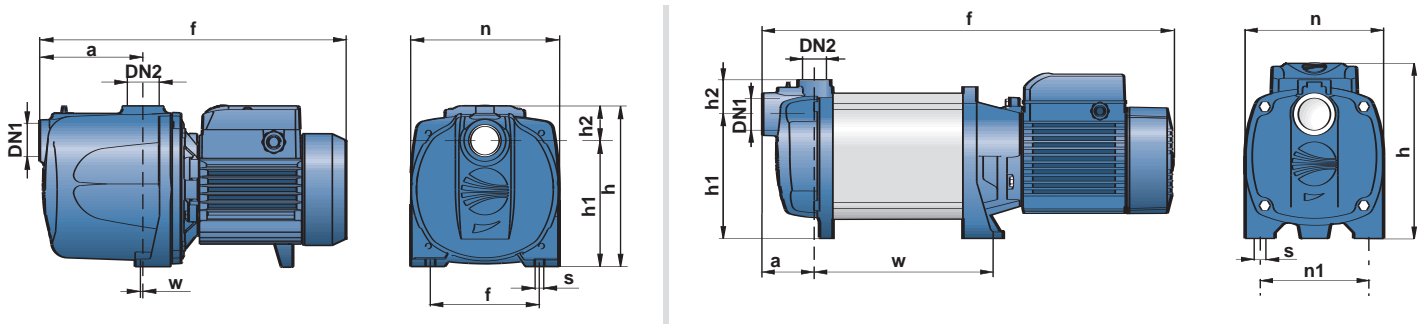

MODEL		SUCTION /DISCH		DIMENSIONS INCHES										LBS	
1 PH	3 PH	DN1	DN2	a	f	h	h1	h2	n	n1	w	s	1~	3~	
PJ20 04	PJ20 04	1"	1"	4.3	13.1	6.8	5.3	1.5	6.2	4.6	0.1	0.4	20.7	19.6	
PJ20 05	PJ20 05	1"	1"	5.3	14.4 /14.1	6.8	5.3	1.5	6.2	4.6	0.1	0.4	23.8	22.5	
PJ20 10	PJ20 10	1 1/4"	1"	2.7	25.0	9.1	6.0	1.8	7.3	5.7	12.0	0.4	56.3	51.9	
PJ20 15	PJ20 15	1 1/4"	1"	2.7	26.2	9.1	6.0	1.8	7.3	5.7	13.2	0.4	60.7	59.6	

CURVES AND PERFORMANCE DATA

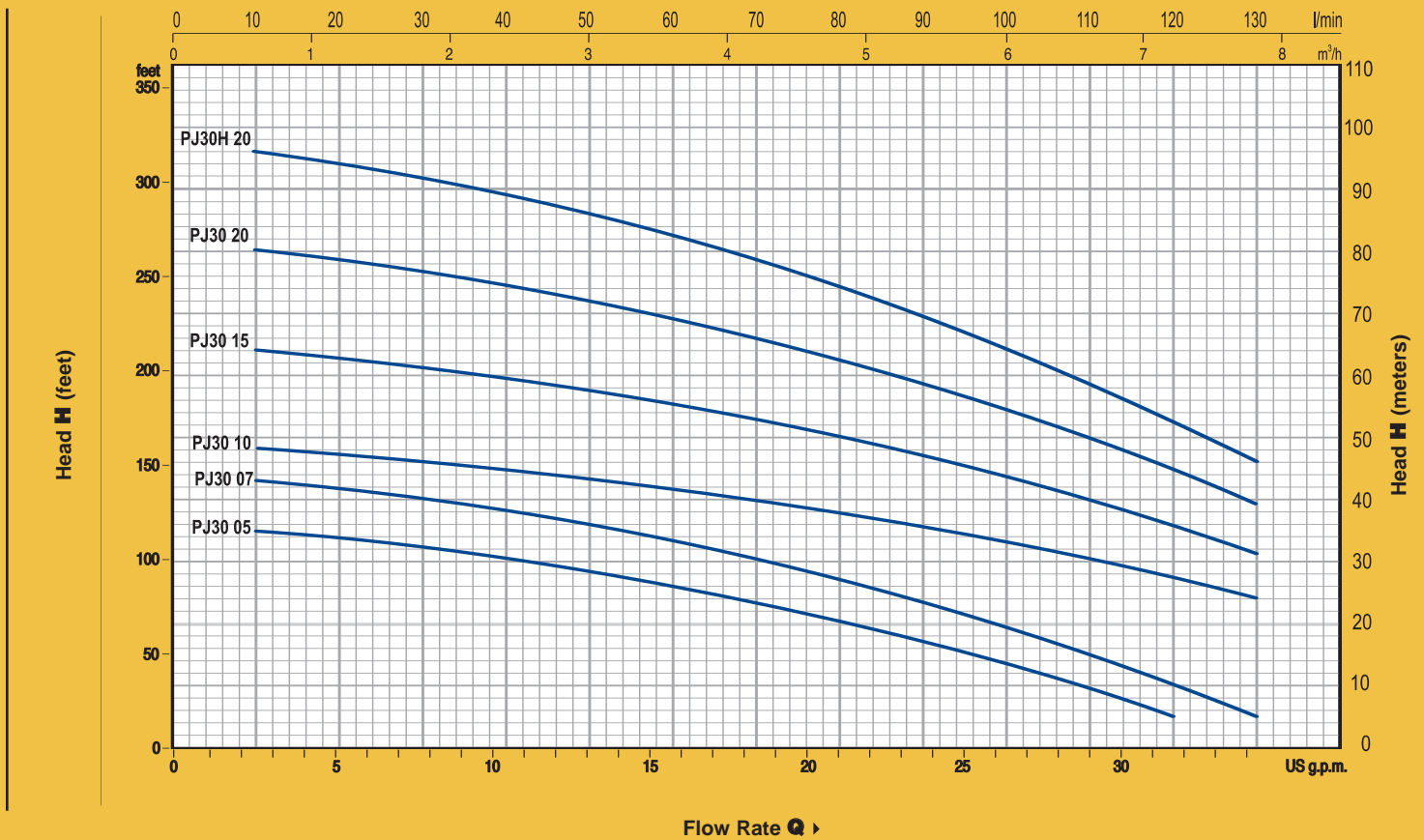

MODEL		HP	FLOW RATE GPM															
1 PH	3 PH		FLOW RATE l/min															
				0	1.3	2.6	5.2	7.9	10.6	13	15	18	21	26	31	34		
				0	5	10	20	30	40	50	60	70	80	100	120	130		
			H Feet	118	117	115	110	105	99	92	85	76	66	44	16			
PJ30 05	PJ30 05	0.5		151	148	141	138	131	125	117	108	99	87	62	33	16		
PJ30 07	PJ30 07	0.7		164	163	161	158	151	148	145	140	133	126	112	89	79		
PJ30 10	PJ30 10	1.0		214	214	210	207	204	197	191	184	174	164	141	115	102		
PJ30 15	PJ30 15	1.5		266	266	263	260	253	246	240	230	217	207	177	145	128		
PJ30 20	PJ30 20	2.0		319	319	315	312	302	296	286	273	260	246	210	171	151		
	PJ30H 20	2.0																

DIMENSIONS AND WEIGHT

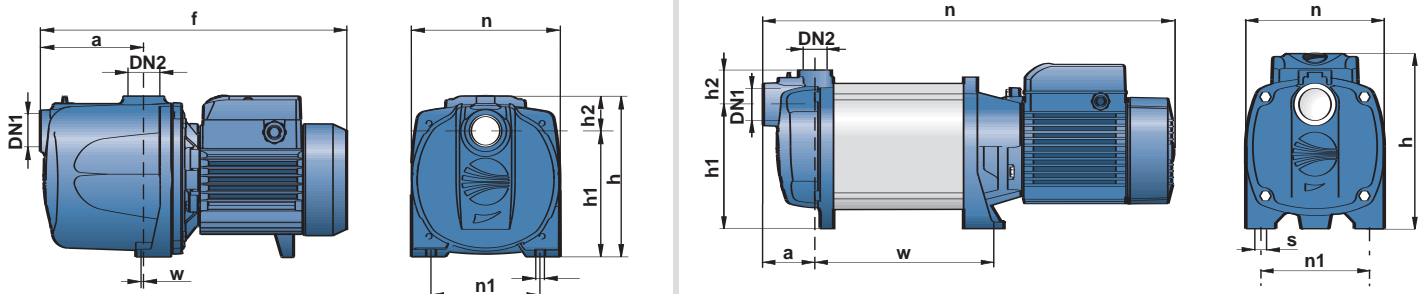

MODEL		SUCTION / DISCH		DIMENSIONS INCHES										LBS	
1 PH	3 PH	DN1	DN2	a	f	h	h1	h2	n	n1	w	s	1~	3~	
PJ30 05	PJ30 05	1"	1"	4.3	13.5 / 13.1	6.8	5.3	1.5	6.2	4.6	0.1	0.4	22.5	20.7	
PJ30 07	PJ30 07	1"	1"	5.3	14.9	7.5	5.3	2.4	6.2	4.6	0.1	0.4	29.6	27.1	
PJ30 10	PJ30 10	1 1/4"	1"	2.7	22.5	9.1	6.0	1.8	7.3	5.7	9.5	0.4	51.9	47.7	
PJ30 15	PJ30 15	1 1/4"	1"	2.7	23.7	9.1	6.0	1.8	7.3	5.7	10.7	0.4	57.2	55.2	
PJ30 20	PJ30 20	1 1/4"	1"	2.7	25.0	9.1	6.0	1.8	7.3	5.7	12.0	0.4	60.7	59.6	
	PJ30H 20	1 1/4"	1"	2.7	26.2	9.1	6.0	1.8	7.3	5.7	13.2	0.4		64.0	

CURVES AND PERFORMANCE DATA

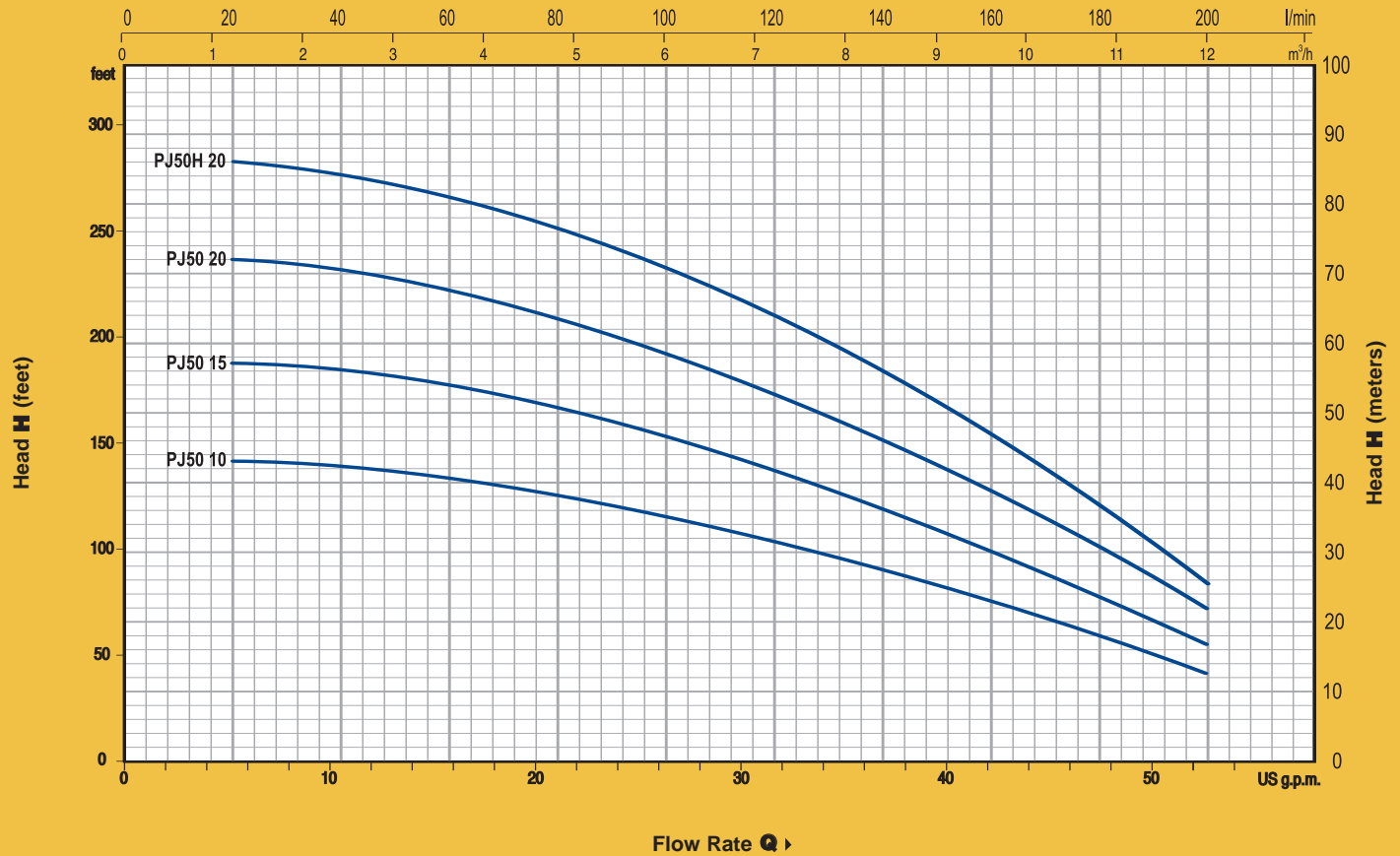

MODEL		HP	FLOW RATE GPM	FLOW RATE l/min															
1 PH	3 PH			0	5	10	13	15	21	26	31	37	42	47	52				
PJ50 10	PJ50 10	1	H Feet	148	141	138	135	131	125	115	105	92	76	59	43				
PJ50 15	PJ50 15	1.5		191	187	181	177	174	161	148	131	115	99	79	56				
PJ50 20	PJ50 20	2		240	233	227	223	217	204	184	168	145	125	99	72				
	PJ50H 20	2		286	279	269	263	256	240	220	197	174	148	118	85				

DIMENSIONS AND WEIGHT

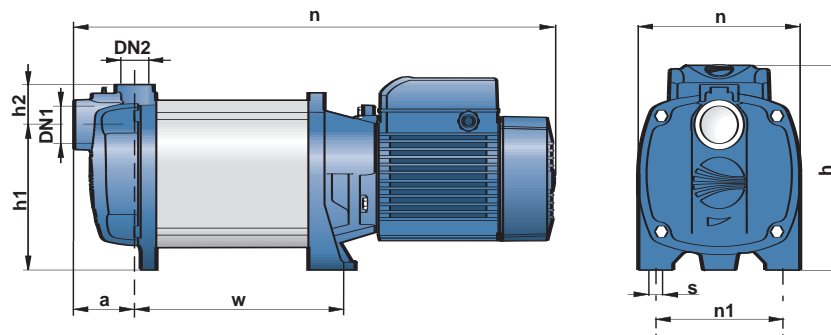

MODEL		SUCTION /DISCH		DIMENSIONS INCHES									LBS	
1 PH	3 PH	DN1	DN2	a	f	h	h1	h2	n	n1	w	s	1~	3~
PJ50 10	PJ50 10	1 1/4"	1"	2.7	22.5	9.1	6.0	1.8	7.3	5.7	9.5	0.4	51.9	47.7
PJ50 15	PJ50 15	1 1/4"	1"	2.7	23.7	9.1	6.0	1.8	7.3	5.7	10.7	0.4	57.2	55.2
PJ50 20	PJ50 20	1 1/4"	1"	2.7	25.0	9.1	6.0	1.8	7.3	5.7	12.0	0.4	60.7	59.6
	PJ50H 20	1 1/4"	1"	2.7	26.2	9.1	6.0	1.8	7.3	5.7	13.2	0.4		64.0