



## close-coupled centrifugal pumps with threaded ports



**Electric pumps with high efficiency motor for reduced energy consumption**

### RANGE OF PERFORMANCE

Flow rate up to 240 gpm  
Head up to 246 ft

### LIMITS OF USE

Manometric suction lift up to 23 ft  
Liquid temperature up to + 195°F  
Environment temperature up to + 104°F

### CONSTRUCTION AND SAFETY STANDARDS

EN 60034-1  
IEC 34-1  
CEI 2-3



### INSTALLATION AND USE

They are recommended for pumping clean water and liquids that are chemically non aggressive to the materials from which the pump is made. **RELIABLE AND MAINTENANCE FREE THEY ARE WIDELY USED IN THE CIVIL, AGRICULTURAL AND INDUSTRIAL SECTORS, FOR SUPPLYING WATER, FOR CONDITIONING OR COOLING SYSTEMS, FOR IRRIGATION, ETC.**

The pumps must be installed in enclosed places, or at least protected against inclement weather.

**GUARANTEE 2 YEARS** subject to our general terms of use

### CONSTRUCTION CHARACTERISTICS

- **PUMP BODY:** cast iron, with threaded ports.
- **BODY BACK-PLATE:** cast iron.
- **IMPELLER:** brass for pumps up to 12.5 HP.
- **IMPELLER:** cast iron for pumps from 15 to 25 HP.
- **MOTOR SHAFT:** stainless steel EN 10088-3 - 1.4104.
- **MECHANICAL SEAL:** ceramic - graphite - NBR.
- **ELECTRIC MOTOR:** the pumps are close-coupled to a carefully matched PEDROLLO electric motor, **with high efficiency (class "EFF1")**, quiet running, totally enclosed fan cooled (TEFC), suitable for continuous duty.  
**CP:** three-phase 230/460 V - 60 Hz
- **INSULATION:** class F. • **PROTECTION IP 44.**
- **REGISTERED MODEL n° 72753**
- **PATENTED ELECTRIC MOTOR**

### OPTIONS ON REQUEST

- ⇒ pump shaft in stainless steel EN 10088-3 - 1.4401 (AISI 316)
- ⇒ special mechanical seal
- ⇒ protection IP 55
- ⇒ other voltages or frequency 50 Hz

**GENERAL PERFORMANCE DATA**

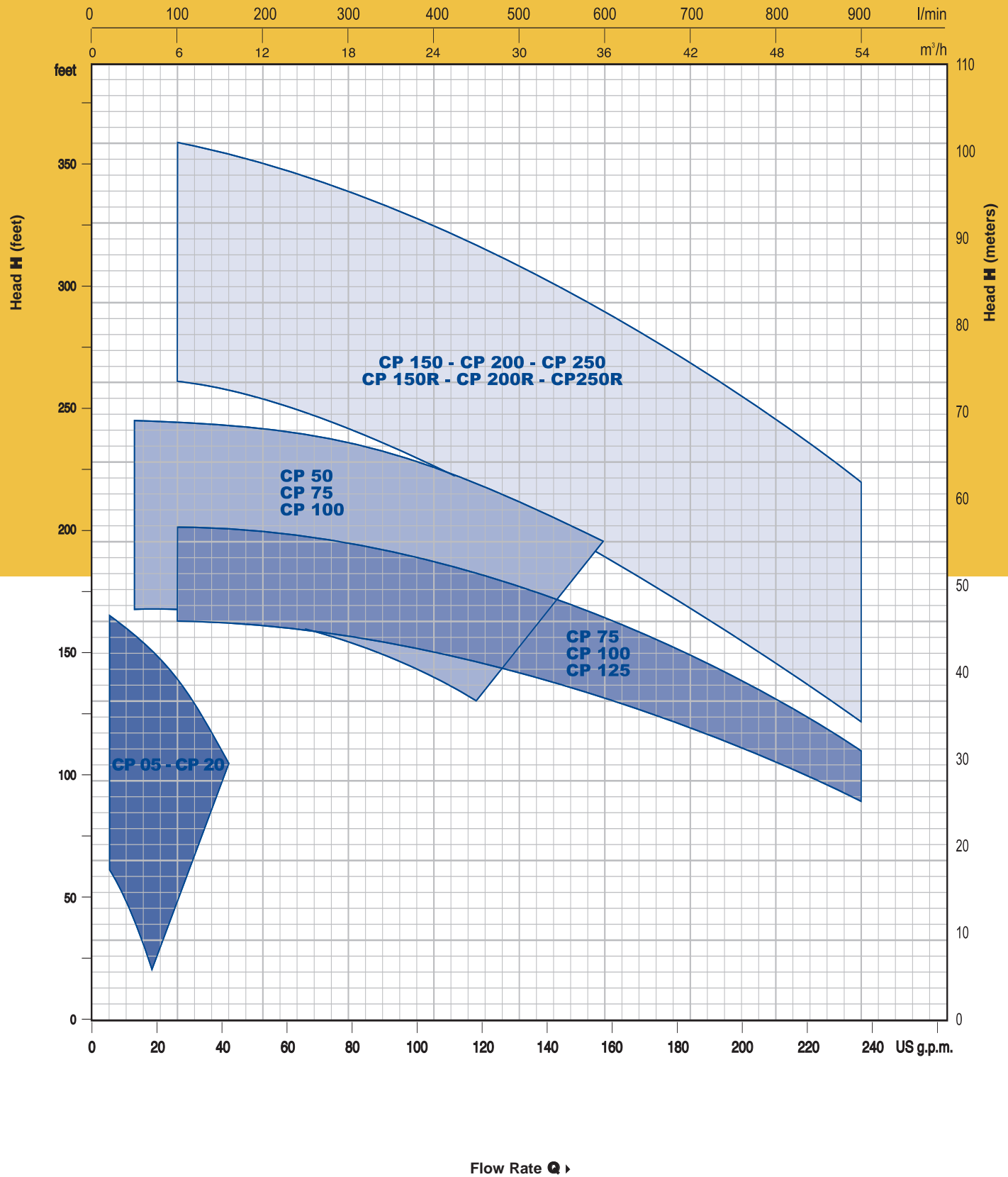

**CURVES AND PERFORMANCE DATA**

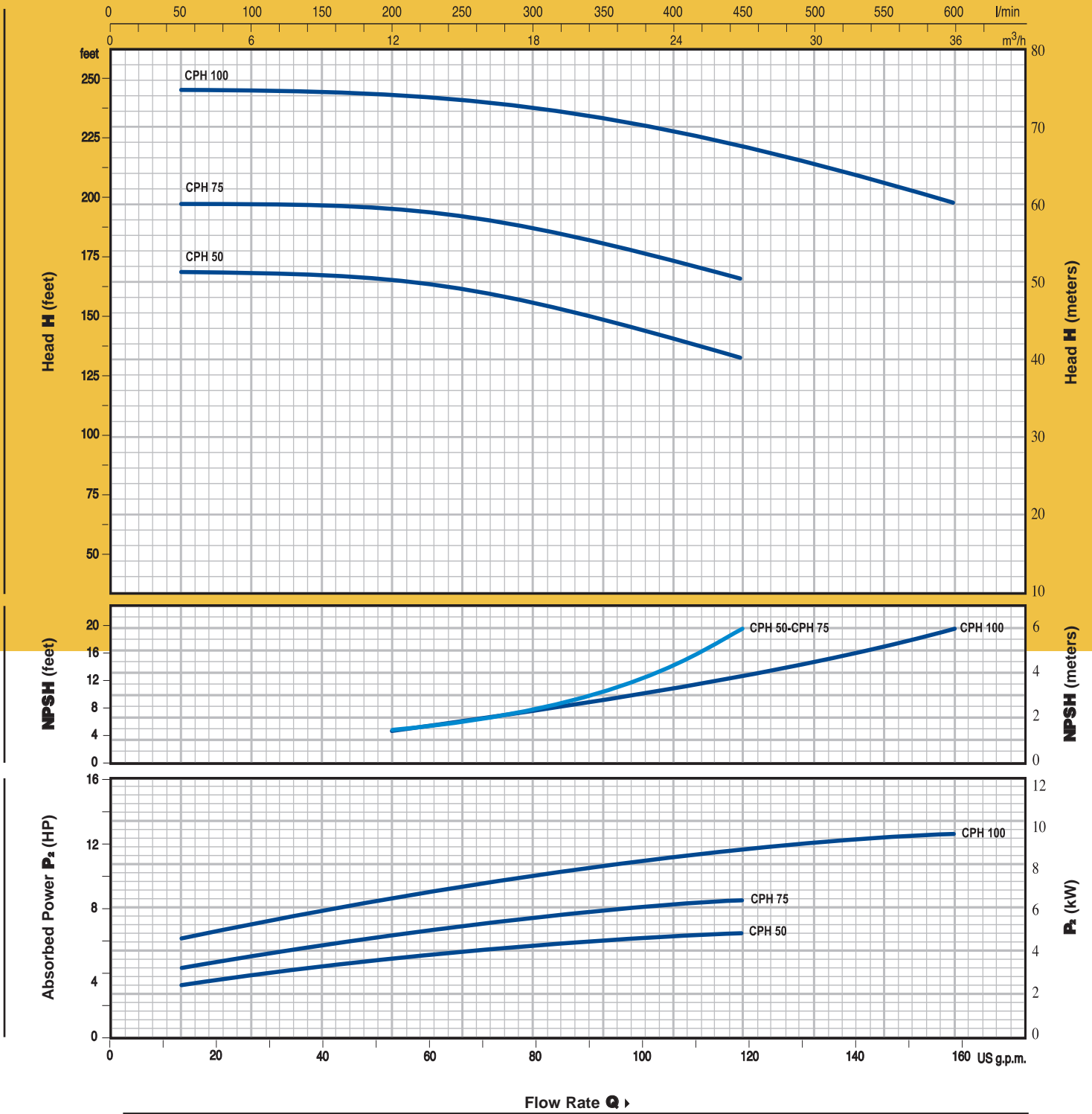

MODEL		HP	FLOW RATE GPM	0	13	26	39	52	66	79	92	105	119	132	145	158
1 PH	3 PH		FLOW RATE l/min	0	50	100	150	200	250	300	350	400	450	500	550	600
CPH 50	CPH 50	5	H Feet	171	169	168	167	165	161	156	148	141	131			
	CPH 75	7.5		197	197	197	195	196	192	187	181	172	166			
	CPH 100	10		246	246	245	244	243	241	238	233	225	221	214	206	197

**CURVES AND PERFORMANCE DATA**

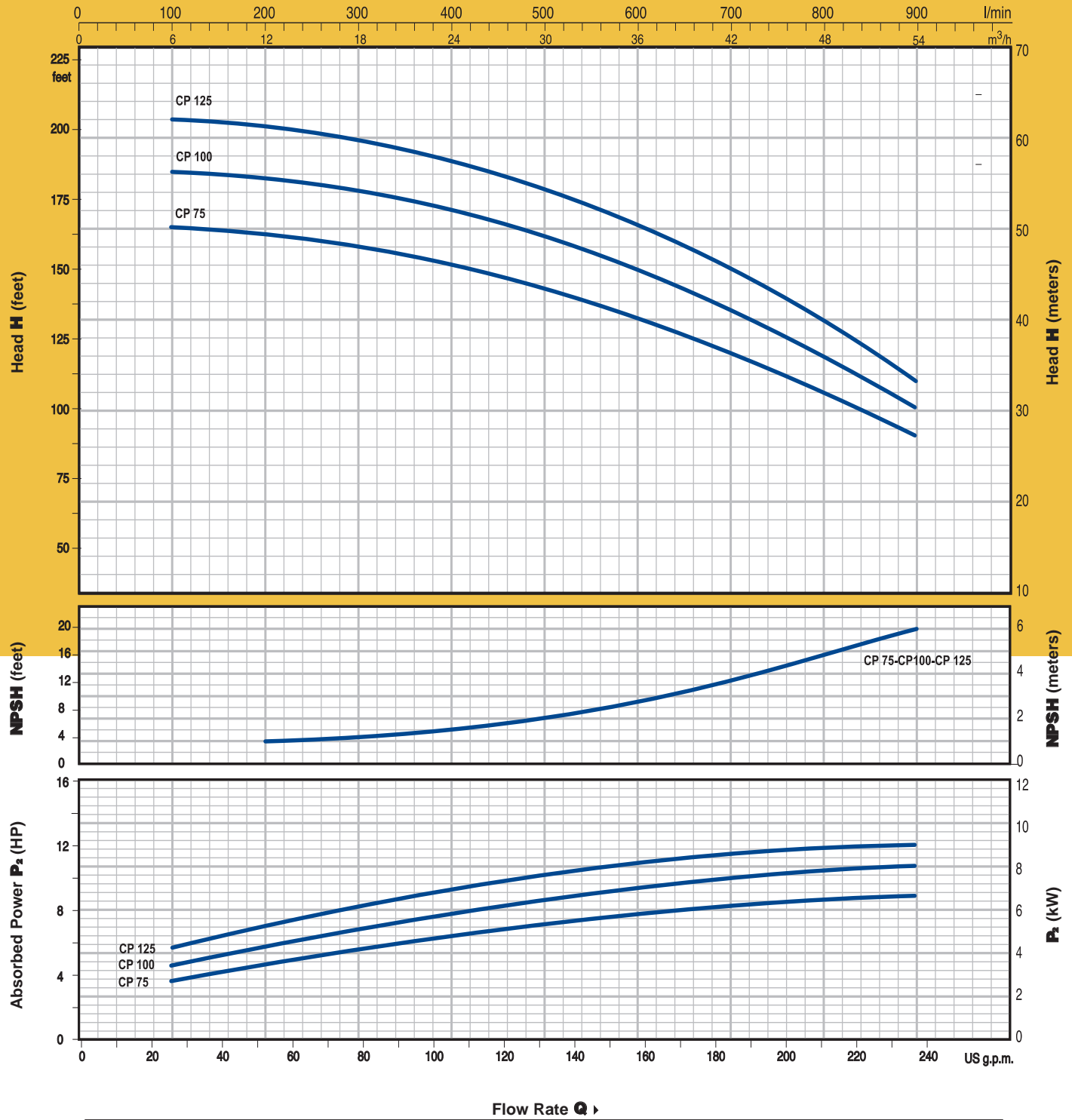

MODEL	HP	FLOW RATE GPM	0.0	26	52	79	105	132	158	185	211	238
		FLOW RATE l/min	0	100	200	300	400	500	600	700	800	900
CP 75	7.5	H Feet	168	164	195	158	151	143	131	119	105	90
CP 100	10		186	184	182	177	171	161	149	135	118	100
CP 125	12.5		204	204	202	197	189	179	166	149	130	109

# CURVES AND PERFORMANCE DATA

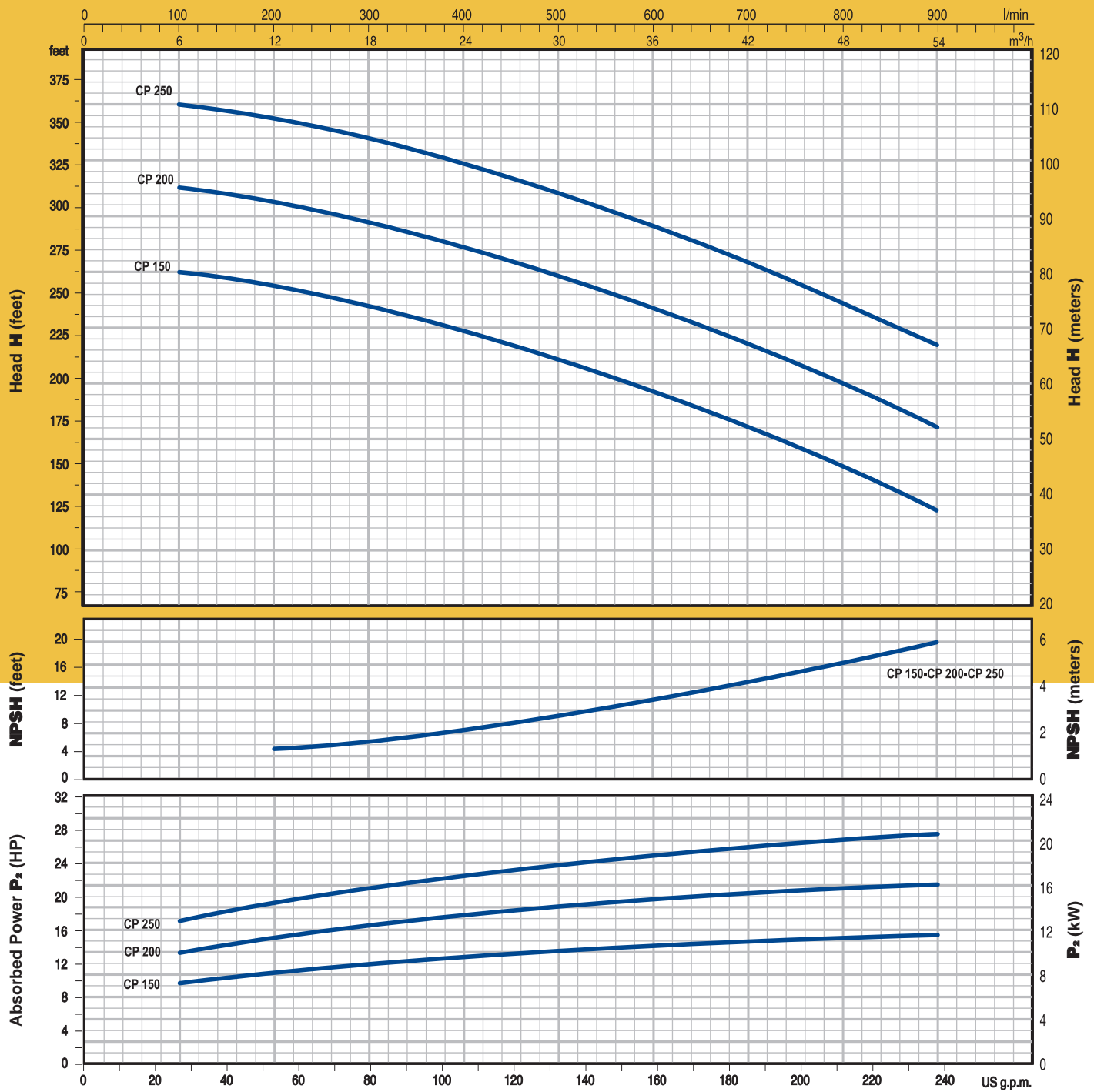

MODEL	HP	FLOW RATE										
		0	26	52	79	105	132	158	185	211	238	
		FLOW RATE l/min	0	100	200	300	400	500	600	700	800	900
CP-CPR 150	15	H Feet	263	263	263	243	227	210	191	171	148	122
CP-CPR 200	20		312	312	312	292	276	260	240	220	197	171
CP-CPR 250	25		361	361	361	342	325	309	289	269	246	220



## DIMENSIONS AND WEIGHT

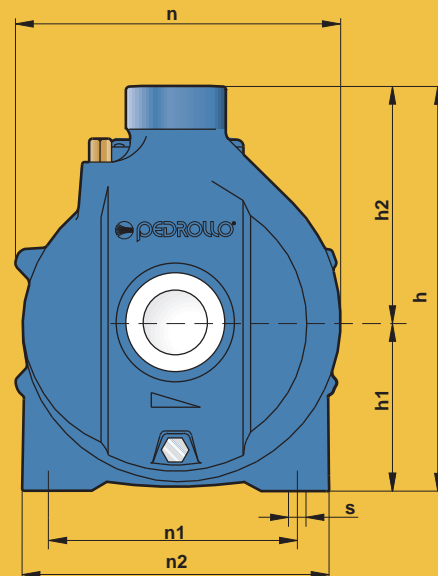
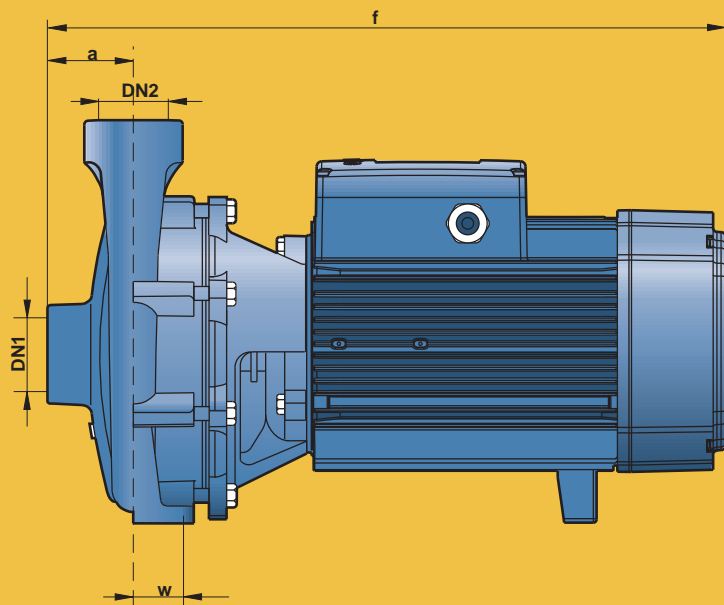

MODEL		SUCTION /DISCH		DIMENSIONS INCHES										LBS
1 PH	3 PH	DN1	DN2	a	f	h	h1	h2	n	n1	n2	w	s	3~
CPH 50		2"	2"	2.8	19.9	12.9	5.4	7.6	10.7	7.5	9.8	1.6	0.6	105.2
	CPH 50	2"	2"	2.8	18.1	12.9	5.4	7.6	10.7	7.5	9.8	1.6	0.6	94.1
	CPH 75	2"	2"	2.8	19.9	12.9	5.4	7.6	10.7	7.5	9.8	1.6	0.6	105.2
	CPH 100	2"	2"	2.8	19.9	12.9	5.4	7.6	10.7	7.5	9.8	1.6	0.6	114.9
	CP 75	2"	2"	2.8	19.9	12.9	5.4	7.6	10.7	7.5	9.8	1.6	0.6	105.2
	CP 100	2"	2"	2.8	19.9	12.9	5.4	7.6	10.7	7.5	9.8	1.6	0.6	114.9
	CP 125	2"	2"	2.8	19.9	12.9	5.4	7.6	10.7	7.5	9.8	1.6	0.6	116.0
	CP 150	2"	2"	2.6	23.5	15.4	6.3	9.1	12.7	9.1	11.6	1.8	0.6	227.6
	CP 200	2"	2"	2.6	27.3	15.4	6.3	9.1	12.7	9.1	11.6	1.8	0.6	265.2
	CP 250	2"	2"	2.6	27.3	15.4	6.3	9.1	12.7	9.1	11.6	1.8	0.6	293.9
	CPR 150	4"	3"	3.6	23.5	15.4	6.3	9.1	12.7	9.1	11.6	1.8	0.6	236.5
	CPR 200	4"	3"	3.6	27.3	15.4	6.3	9.1	12.7	9.1	11.6	1.8	0.6	274.0
	CPR 250	4"	3"	3.6	27.3	15.4	6.3	9.1	12.7	9.1	11.6	1.8	0.6	302.8